

T2™

# Tibial Nailing System

Operative Technique



# Tibial Nailing System

## Contributing Surgeons :

---

### **Prof. Dr. med. Volker Bühren**

Chief of Surgical Services  
Medical Director of Murnau Trauma Center  
Murnau, Germany

---

### **Kyle F. Dickson, M.D.**

Director of Surgery & Chief of Orthopaedics  
Charity Hospital  
Associate Professor & Director of Orthopaedic Trauma  
Tulane University  
Assistant Clinical Professor  
Louisiana State University  
New Orleans, Louisiana  
USA

---

### **Paul Tornetta, III, M.D.**

Director of Orthopaedic Trauma, Boston Medical Center  
Professor and Vice Chairman  
Department of Orthopaedic Surgery  
Boston University School of Medicine  
Boston, Massachusetts  
USA

---

This publication sets forth detailed recommended procedures for using Stryker Trauma devices and instruments.

It offers guidance that you should heed, but, as with any such technical guide, each surgeon must consider the particular needs of each patient and make appropriate adjustments when and as required.

A workshop training is required prior to first surgery.

# Contents

<b>1.</b>	<b>Introduction</b>	<b>4</b>
1.1.	Implant Features	4
1.2.	Instrument Features	6
1.3.	References	6
<b>2.</b>	<b>Indications</b>	<b>7</b>
<b>3.</b>	<b>Pre-operative Planning</b>	<b>7</b>
<b>4.</b>	<b>Operative Technique</b>	<b>8</b>
4.1.	Patient Positioning Options and Reduction	8
4.2.	Incision	8
4.3.	Entry Point	8
4.4.	Unreamed Technique	9
4.5.	Reamed Technique	9
4.6.	Nail Selection	10
4.7.	Nail Insertion	10
4.8.	Guided Locking Mode (via Target Device)	13
4.9.	Static Locking Mode	14
4.10.	Freehand Distal Locking	16
4.11.	End Cap Insertion	17
4.12.	Dynamic Locking Mode	18
4.13.	Apposition/Compression Locking Mode	18
4.14.	Advanced Locking Mode	20
4.15.	Nail Removal	21
4.16.	Blocking Screw Technique (optional)	22
<hr/>		
	<b>Ordering Information – Implants</b>	<b>24</b>
	<b>Ordering Information – Instruments</b>	<b>28</b>

# Introduction

## 1. Introduction

The T2™ Tibial Nailing System represents the latest and most comprehensive development of the original intramedullary principles presented by **Prof. Gerhard Küntscher in 1940**. Stryker Trauma has created a **new generation locking nail system**, bringing together all the capabilities and benefits of separate nailing systems to create a single, integrated surgical resource for fixation of long bone fractures.

The T2™ Tibial Nailing System offers the competitive advantages of:

- **Not limiting the approach to a certain nailing technique.**
- **Accommodating reamed or unreamed procedures.**
- **Providing locking options for all types of fractures, plus the Advanced Locking Mode for increased rotational stability.**

Through the development of a common, streamlined and intuitive surgical approach, both in principle and in detail, the T2™ Tibial Nailing System offers **significantly increased speed and functionality** for the treatment of fractures as well as simplifying the training requirements for all personnel involved.

### 1.1. Implant Features

The T2™ Tibial Nailing System is the realization of superior biomechanical intramedullary stabilization using small caliber, strong cannulated implants for internal fixation of long bones.

According to the fracture type, the system offers the option of **different locking modes**. In addition to **static locking, a controlled dynamization with rotational stability is optional**.

In some indications, a **controlled apposition/compression of bone fragments can be applied by introducing a Compression Screw from the top of the nail**. To further increase rotational stability, the nail can be locked statically after using the controlled dynamization and apposition/compression option.

The **Compression Screw is pushed against the proximal Partially Threaded Locking Screw** that has been placed in the oblong hole, **drawing the distal segment towards the fracture site**. In stable fractures, this has the biomechanical advantage of **creating active circumferential compression** to the fracture site, **transferring axial load to the bone**, and reducing the function of the nail as a load bearing device (1).

This ability to **transfer load back to the bone** can reduce the incidence of implant failure secondary to fatigue. Typical statically locked nails function as load bearing devices and failure rates in excess of 20% have been reported (2).

The beneficial effect of apposition/compression in treating long bone fractures in cases involving transverse and short oblique fractures that are axially stable is well documented (3, 4).

In addition to the T2™ **Standard Tibial Nail** that features options to address very proximal and very distal fractures as well as the advanced compression feature, there are **two additional Tibial Nail designs** available on a special order basis that address specific surgical indications:

The T2™ **Distal Tibial Nail**, available in 10mm diameter only, may be used for very distal fractures\*. As with the Standard Nail, an oblong hole is located in the proximal third of the nail for optional controlled

dynamization and apposition/compression. Compared to the Standard Nail, the oblong hole is 7mm further distal, ending just above the Herzog 10° bend. The Distal Tibial Nail has 2 distal locking holes at 5mm and 13mm centered from the distal tip.

The T2™ **Proximal Tibial Nail** may also be used for very proximal and very distal fractures. The Proximal Tibial Nail does not feature an oblong hole for optional controlled dynamization and apposition/compression. The location of the 3 distal locking holes is the same as the Standard Nail.

#### **Note:**

**All three nail designs feature the distal most hole centered at 5mm from the distal tip to better address hard to reach distal fractures.**

**Common 5mm cortical screws** simplify the surgical procedure and promote a minimally invasive approach. **Fully Threaded Locking Screws** are available for regular locking procedures. **Partially Threaded Locking Screws (Shaft Screws)** are designed for use if apposition/compression is applied.

#### **Note:**

**The 8mm T2™ Tibial Nail can only be locked distally with 4mm Fully Threaded screws. As with all diameters of T2™ Tibial Nails, the proximal screws are 5mm.**

One **common Compression Screw** to close the fracture site, and **End Caps** in eight sizes are available to provide a **“best fit” for every indication**.

All implants in the T2™ Tibial Nailing System are **gun-drilled** and made of **Type II anodized titanium alloy (Ti6AL4V) for enhanced biomechanical and biomedical performance**.

\* The Distal Tibial Nail is not cleared for primary ankle arthrodesis in the U.S.

# Technical Details

## Nails

Diameters 8\*-15mm  
 Sizes 240-420mm

10° A/P slope

### Note:

Screw Length is measured from top of head to tip.

### 5.0mm Fully Threaded Locking Screws

L = 25-120mm

### 4.0mm Fully Threaded Locking Screws for 8mm Nails (Distal Holes Only)

L = 20-60mm

### 5.0mm Partially Threaded Locking Screws (Shaft Screws)

L = 25-120mm

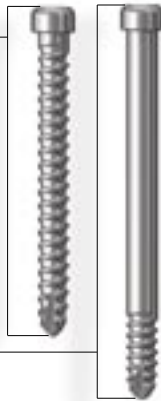

### Tibia Advanced Compression Screw



### End Caps

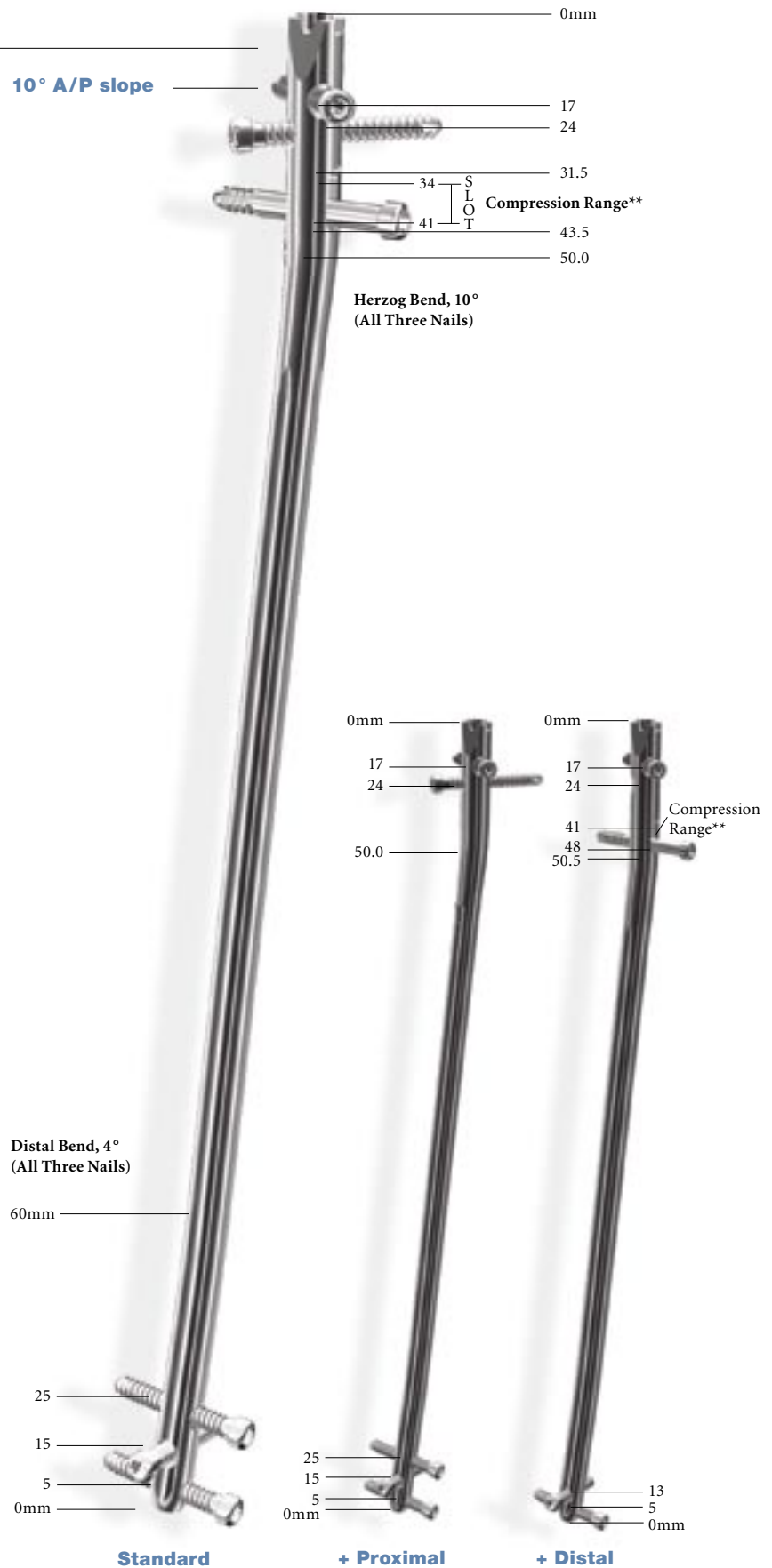

#### \*\* Compression Range

Total Length of Slot	12mm
Less Screw Diameter (-)	5mm
Maximum Movement of Screw	7mm

\* 8mm nails require 4mm Fully Threaded Screws for Distal Locking  
 + Proximal and Distal Nails are available as special order implants

# Features

## 1.2. Instrument Features

The major advantage of the instrument system is a breakthrough in the integration of the instrument platform which can be used not only for the complete T2™ Nailing System, but will be the platform for all future nailing systems, thereby reducing complexity and inventory.

The innovative instrument platform offers advanced precision and usability, and features ergonomically styled targeting devices.

In addition to the advanced precision and usability, the instruments are both color, number and symbol coded to indicate its usage during the surgical procedure.

Color and number coding indicates the step during the procedure in which the instrument is used. This color code system is marked on the trays to easily identify the correct instrument.

Step	Color	Number
Opening	Red	①
Reduction	Brown	②
Nail Introduction	Green	③
Guided Locking	Light Blue	④
Freehand Locking	Dark Blue	⑤

Symbol coding on the instruments indicates the type of procedure, and must not be mixed.

### Symbol

- Square = Long instruments, Femur
- ▲ Triangular = Short instruments, Tibia and Humerus

### Drills

#### Drills feature color-coded rings:

4.2mm = **Green**

For 5.0mm Fully Threaded Locking Screws and for the second cortex when using 5.0mm Partially Threaded Locking Screws (Shaft Screws).

5.0mm = **Black**

For the first cortex when using 5.0mm Partially Threaded Locking Screws (Shaft Screws).

3.5mm = **Orange**

For 4.0mm Fully Threaded Locking Screws for the distal holes only of the 8mm Tibial Nail.

## 1.3. References

1. T. E. Richardson, M. Voor, D. Seligson, Fracture Site Compression and Motion with Three Types of Intramedullary Fixation of the Femur, Osteosynthese International (1998), 6: 261-264.

2. Hutson et al., Mechanical Failures of Intramedullary Tibial Nails Applied without Reaming, Clin. Orthop. (1995), 315: 129-137.

3. M. E. Müller, et al. Manual of Internal Fixation, Springer-Verlag, Berlin.

4. O. Gonschorek, G. O. Hofmann, V. Bühren, Interlocking Compression Nailing: a Report on 402 Applications, Arch. Orthop. Trauma Surg (1998), 117: 430-437.

5. Mehdi Mousavi, et al., Pressure Changes During Reaming with Different Parameters and Reamer Designs, Clinical Orthopaedics and Related Research, Number 373, pp. 295-303, 2000.

6. Tibial Portal Placement: The Radiographic Correlate of the Anatomic Safe Zone, Timothy McConnell, Paul Tornetta III, John Tizley, David Casey, Journal of Orthopaedic Trauma, Vol. 15, No. 3, pp. 207-209

7. Stedtfeld H.-W., Rapke C., Jurowich B. Besonderheiten der Verriegelungsnagelung proximaler Tibiaschaftfrakturen. Osteosynthese International 1995; 4: 264-270.

8. Stedtfeld H.-W. Die transmedulläre Stützschraube. Osteosynthese International (Suppl 1) 2000; 8: 170-172.

# Indications

## 2. Indications

The T2™ Tibial Nailing System is indicated for:

- Open or closed shaft fractures with a very proximal and very distal extent in which locking screw fixation can be obtained
- Multi-fragment fractures
- Segmental fractures
- Proximal or distal non-unions
- Proximal or distal mal-unions
- Pseudarthrosis
- Corrective osteotomies
- Pathologic and impending pathologic fractures
- Tumor resections
- Comminuted fractures with or without bone loss
- Primary ankle arthrodesis\*.



## 3. Pre-Operative Planning

An X-Ray Template (1806-0000 for Standard and Proximal nails, 1806-0001 for Distal nails) is available for pre-operative planning.

Thorough evaluation of preoperative radiographs of the affected extremity is critical. Careful radiographic examination can prevent intra-operative complications.

For standard mid-shaft fractures, the proper nail length should extend from just below the Tibial Plateau at the appropriate medio-lateral position to just proximal to the Epiphyseal Scar of the ankle joint.

This allows the surgeon to consider the apposition/compression feature of the T2™ Standard Tibial Nail and T2™ Distal Tibial Nail knowing that 7mm of active apposition/compression is possible, prior to determining the final length of the implant. If apposition/compression is planned, the nail should be at least 7mm shorter.

**Note:**  
Check with local representative regarding availability of sizes and nail types.

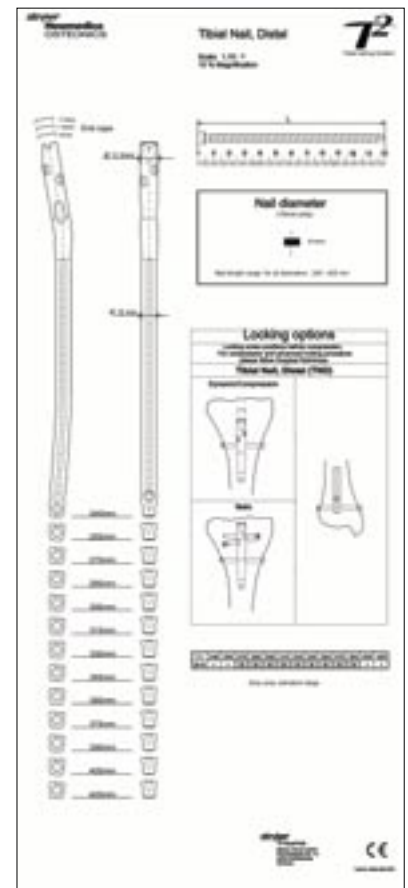
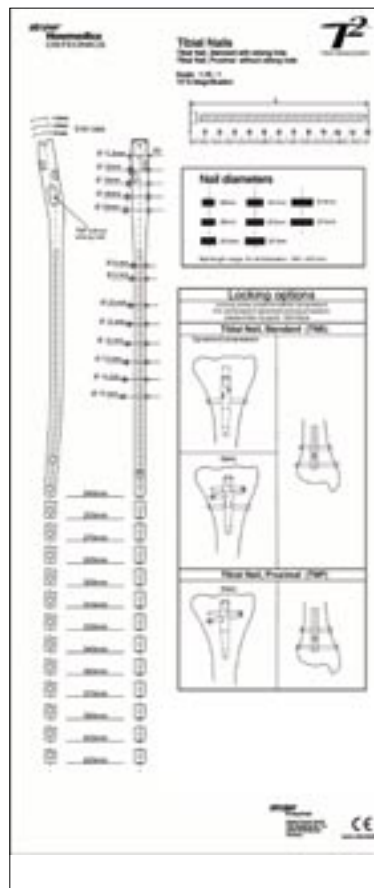

\* This indication is not cleared for use in the U.S.

# Operative Technique

## 4. Operative Technique

### 4.1. Patient Positioning Options and Reduction

a) The patient is placed in the supine position on a radiolucent fracture table and the leg is hyperflexed on the table with the aid of a leg holder, or b) The leg is free draped and hung over the edge of the table (Fig. 1).



Fig. 1

The knee is flexed to  $>90^\circ$ . A triangle may be used under the knee to accommodate flexion intra-operatively. It is important that the knee rest is placed under the posterior aspect of the lower thigh in order to reduce the risk of vascular compression and of pushing the proximal fragment of the tibia anteriorly.

Anatomical reduction can be achieved by internal or external rotation of the fracture and by traction, adduction or abduction, and must be confirmed under image intensification. Draping must leave the knee and the distal end of the leg exposed.

### 4.2. Incision

Based on radiological image, a paratenonous incision is made from the patella extending down approximately 1.5–4cm in preparation of nail insertion. The Patellar Tendon may be retracted laterally or split at the junction of the medial third, and lateral two-thirds of the Patellar Ligament. This determines the entry point (Fig. 2).

### 4.3. Entry Point

The medullary canal is opened through a superolateral plateau entry portal. The center point of the portal is located slightly medial to the lateral tibial spine as visualized on the A/P radiograph and immediately adjacent and anterior to the anterior articular margin as visualized on the true lateral radiograph. It is located lateral to the midline of the tibia by an average of 6 percent of the tibial plateau width. Radiographic confirmation of this area is essential to prevent damage to the intra-articular structure during portal placement and nail insertion (Fig. 3). The opening should be directed with a

central orientation in relation to the medullary canal. After penetrating the cortex with the 3×285mm K-Wire (1806-0050S), the Ø10mm Rigid Reamer (1806-2010) or the “special order” Ø11.5 Rigid Reamer (1806-2011) is used to access the medullary canal (Fig. 4). Alternatively, to penetrate the cortex, the Ø10mm Straight (1806-0045), “special order” Ø11.5mm Straight (1806-0047), or Curved (1806-0040) Awl may be used (Fig. 5).

#### Note:

A more distal entry point may result in damage to the posterior cortex during nail insertion.

#### Note:

Guiding the Rigid Reamer over the K-Wire prior to K-Wire insertion within the Proximal Tibia will help to keep it straight while guiding the opening instrument centrally towards the canal. Do not use bent K-Wires.

#### Note:

During opening the entry portal with the Awl, dense cortex may block the tip of the Awl. An Awl Plug (1806-0032) can be inserted through the Awl to avoid penetration of bone debris into the cannulation of the Awl shaft.



Fig. 2

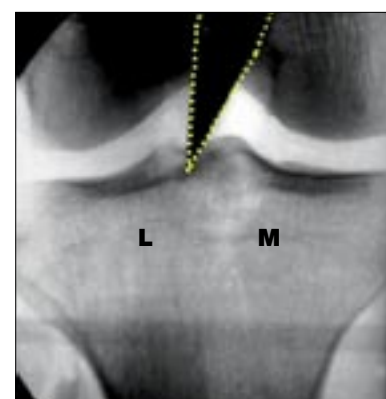

Fig. 3



Fig. 4



Fig. 5

# Operative Technique

## 4.4. Unreamed Technique

If an unreamed technique is preferred, the 3×800mm Smooth Tip Guide Wire (1806-0090S) is passed through the fracture site using the Guide Wire Handle (1806-0095 and 1806-0096) (Fig. 6). The Universal Rod (1806-0110) with Reduction Spoon (1806-0125), or the Reduction Tip (special order 1806-0120), may be used as a fracture reduction tool to facilitate Guide Wire insertion (Fig. 7), and as a “sound” to help determine the diameter of the medullary canal. The Universal Rod is 9mm diameter. Internal rotation during insertion will aid in passing the Guide Wire down the tibial shaft. The Guide Wire should lie in the center of the metaphysis and the diaphysis in both the A/P and Lateral views to avoid offset positioning of the nail. The Guide Wire handle is removed leaving the Guide Wire in place.

## 4.5. Reamed Technique

For reamed techniques, the 3 × 800mm Ball Tip Guide Wire (1806-0080S) is inserted through the fracture site. Except for the 8mm Tibial Nails, use of the Ball Tip Guide Wire does not require a Guide Wire exchange. The Universal Rod with Reduction Spoon or Reduction Tip may be used as a fracture reduction tool to facilitate Guide Wire insertion through the fracture site (see Fig. 7).

**Note:**  
The Ball Tip at the end of the Guide Wire will stop the reamer head.

Reaming (Fig. 8) is commenced in 0.5mm increments until cortical contact is appreciated. Final reaming should be 1mm–1.5mm larger than the diameter of the nail to be used.

**Note:**  
The proximal diameter of the 8mm–11mm diameter nails is 11.5mm. Additional proximal metaphyseal reaming may be required to facilitate nail insertion. Nail sizes 12–15mm have a constant diameter.

**Note:**  
8mm Tibial Nails cannot be inserted over the 3×800mm Ball Tip Guide Wire (1806-0080S). The Ball Tip Guide wire must be exchanged for the 3×800mm Smooth Tip Guide Wire (1806-0090S) prior to nail insertion.

## Bixcut™ Reamer

The complete range of Bixcut™ reamers is available with either modular or fixed heads. The optimized cutting flute geometry is designed to reduce intramedullary pressure and temperature. This is achieved by the forward and side cutting face combination of the reamer blades. The large clearance rate resulting from the reduced number of reamer blades, coupled with the reduced length of the reamer head, relieves the intramedullary pressure and provides efficient removal of reamed material. See pages 30–31 for additional Bixcut™ Reamer system details.

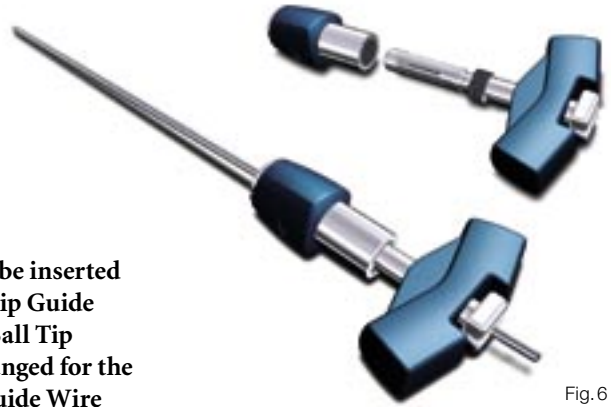

Fig.6



Fig.7

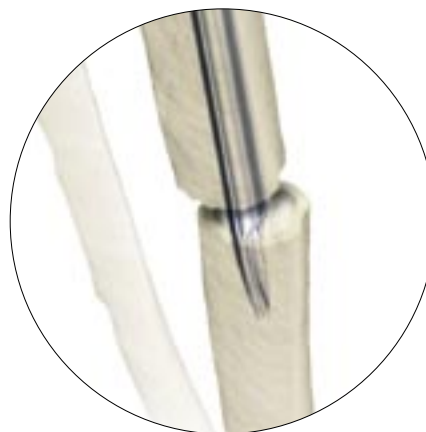

Fig.8

# Operative Technique

## 4.6. Nail Selection

### Diameter

The diameter of the selected nail should be 1–1.5mm smaller than that of the last reamer used.

### Length

The X-Ray Ruler (1806-0010) may be used to determine nail diameter and length. The X-Ray Ruler may also be used as a guide to help determine final Locking Screw positions (Fig. 9).

### Note:

X-Ray Ruler also features Distal Hole Configurations

Alternatively, nail length may be determined by measuring the remaining length of the Guide Wire. The Guide

Wire Ruler (1806-0020) is placed on the Guide Wire and the correct nail length is read at the end of the Guide Wire on the Guide Wire Ruler (Fig. 10).

### Note:

If the fracture is suitable for apposition/compression, the implant selected should be 7–12mm shorter than measured to help avoid migration of the nail beyond the insertion site.

The Guide Wire Ruler is calibrated for 800 and 1000mm Guidewires with markings for the Tibia, Femur and Humerus.

Upon completion of reaming, the appropriate size nail is ready for insertion.

## 4.7. Nail Insertion

The selected nail is assembled onto the Tibial Target Device (1806-1000) with the Tibial Nail Holding Screw (1806-0370) (Fig. 11). Securely tighten the Nail Holding Screw with the Insertion Wrench (1806-0135) so that it does not loosen during nail insertion.

To attach the Nail Handle to the Targeting Arm, turn the Quick-Lock Ring on the Targeting Arm clockwise. Triangles on the Quick-Lock Ring and the Targeting Arm indicate the correct position to attach the Nail Handle when both triangles are in line with each other.

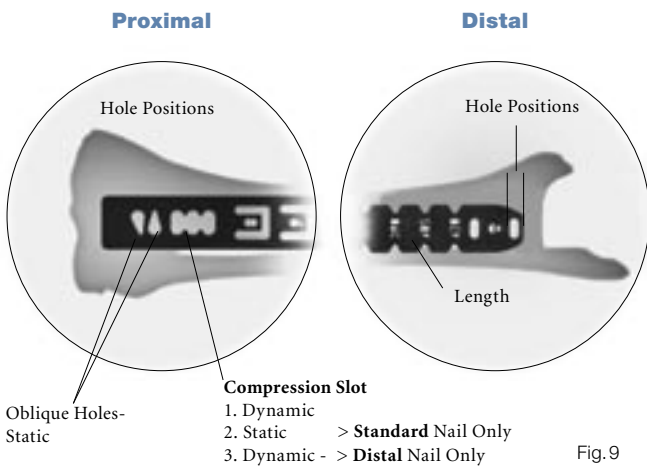

### End of Guide Wire Ruler equals Measurement Reference

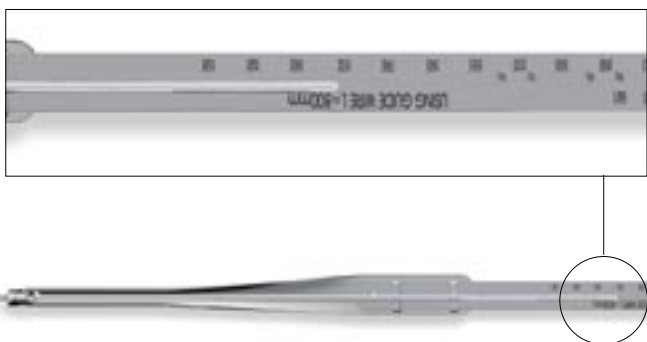

Fig.10

# Operative Technique

## Note:

### Prior to insertion:

1. Recheck that the Nail is tightly secured to the Nail Handle.
2. Verify the hole pattern and appropriate locking options for the Nail type selected. This is extremely important since the proximal hole patterns are different among the Proximal, Standard and Distal Nails.
3. A drill bit may be inserted through the targeting device and through the nail holes to help check alignment and hole configuration.
4. T2™ Tibial nails with diameters 9mm–15mm do not require a Guide Wire exchange.

If a Guide Wire is used, it is important to note that only the 8mm Tibial Nails require exchanging the 3×800mm Ball Tip Guide Wire (1806-0080S) for the 3×800mm Smooth-Tip Guide Wire (1806-0090S) prior to insertion. Use the Teflon Tube (1806-0073S) to facilitate the Guide Wire exchange.

The Strike Plate (1806-0150) is threaded into the Nail Handle next to the Nail Holding Screw.

The Nail is inserted by hand over the 3×800mm Ball Tip Guide Wire (if used) and into the entry site of the proximal tibia (Fig. 12). Gently manipulate the nail to help avoid penetration of the posterior cortex. If the nail is deflected towards the posterior cortex, remove the nail, and hyperflex the knee. Under image control, use a straight reamer to ream an anterior tract in the proximal fragment.

The Nail is advanced through the entry point past the fracture site to the appropriate level. Remove the Guide Wire once the nail is past the fracture site.

The Slotted Hammer can be used on the Strike Plate (Fig. 13) or if dense bone is encountered, alternatively, the Universal Rod may be attached to the Strike Plate and used in conjunction with the Slotted Hammer (1806-0170) to insert the nail (Fig. 14). A captured Sliding Hammer (1806-0175) is available as an “optional” addition to the basic instrument set.



Fig. 12



Fig. 13



Fig. 14

# Operative Technique

The three circumferential grooves on the insertion post act as a guide while inserting the nail to the correct depth. When locking the Tibial Nail in the Static Mode, the nail is countersunk a minimum of 2mm to the chondral surface (Fig. 15). When the implant is inserted in the Dynamic Mode, with active apposition/compression or in the Advanced Locking Mode, the recommended insertion depth is 7 or 12mm based on how much active compression is to be applied (Fig. 16). The final nail depth should be well below the chondral surface to minimize irritation to the Patellar Tendon.



Fig. 15



Fig. 16

Repositioning of the nail should be carried out either by hand or by using the Strike Plate attached to the Target Device. The Universal Rod and Slotted Hammer may then be attached to the Strike Plate to carefully and smoothly retract the assembly. DO NOT hit on the Target Device.

Attach the Targeting Arm to the Nail Handle by rotating the spring loaded Quick-Lock Ring on the Target Arm clockwise while connecting it to the knob on the end of the Nail Handle (Fig. 17).

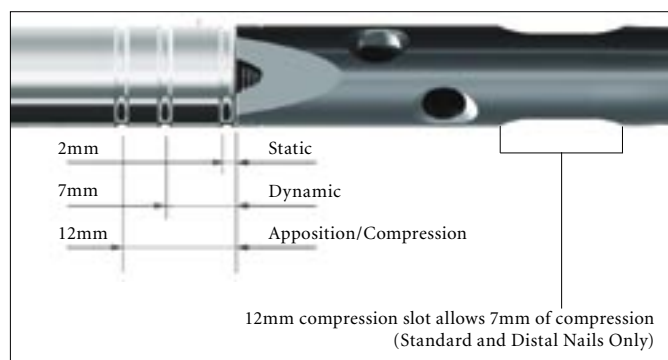

Fig. 16A

**Note:**  
Remove the Guide Wire prior to drilling holes and inserting the Locking Screws.

**Note:**  
A chamfer is located on the proximal end of the nail to help identify the junction of the nail and insertion post under fluoroscopy. Three circumferential grooves are located on the insertion post of the Target Device Assembly at 2mm, 7mm and 12mm from the proximal end of the nail. Depth of insertion may be visualized with the aid of fluoroscopy.

**Note:**  
Compression Slot on the Distal Nail is located 7mm further Distal than on the Standard Nail.



Fig. 17

# Operative Technique

## 4.8. Guided Locking Mode (via Target Device)

Before locking the nail proximally, recheck that the Nail Holding Screw is securely tightened by using the Insertion Wrench, and check that the Target Arm is properly attached to the Nail Handle. The Target Device is designed to provide four options for proximal locking when using the Standard Tibial Nail (Fig. 17.1–17.3).

In Static Locking Mode all three indicated holes may be used (Fig. 17.1).

- 1. Static
- 2. Static
- 3. Static

The dynamic hole is used to lock the nail in the controlled Dynamization or Apposition/Compression Modes (Fig. 17.2).

### 4. Dynamic

Both the dynamic and more proximal of the two oblique locking holes are used in the Advanced Locking Mode. Proper placement of the Advanced Compression Screw against the transverse Partially Threaded Locking Screw (Shaft Screw) will block the more distal of the two oblique locking holes even if fully compressed (Fig. 17.3).

### 4. Dynamic 1. Static

**Note:**  
Any attempt to drill across the more distal of the two oblique locking holes may result in particulate debris generation or a broken drill.

The Short Tissue Protection Sleeve (1806-0180) together with the Short Drill Sleeve (1806-0210) and the Short Trocar (1806-0310) is inserted into the Target Device by pressing the safety clip (Fig. 18). The mechanism will keep the sleeve in place and prevent it from falling out. It will also prevent

the sleeve from sliding during screw measurement. To release the Tissue Protection Sleeve, the safety clip must be pressed again and held while removing the sleeve.

**Note:**  
The Proximal Tibial Nail does not feature a proximal oblong Dynamic/Compression hole. If a Proximal Tibial Nail is implanted, do not attempt to drill through the dynamic and static M/L holes on the Target Device. Only use the number 1 and number 2 static holes. (Fig. 17.1)

**Note:**  
The location of the oblong hole on the Distal Tibial Nail is 7mm more distal than the hole location for the Standard Tibial Nail. If a Distal Tibial Nail is implanted, do not attempt to drill through the Dynamic M/L hole on the Target Device or you will hit the nail. Only use the static holes numbered 1, 2, and 3. (Fig. 17.1)



Fig. 17.1



Fig. 17.3



Fig. 17.2



**Note:**  
For Standard and Distal Nail only.

released

locked

Fig. 18

There are four safety clips

# Operative Technique



Fig. 19



Fig. 20

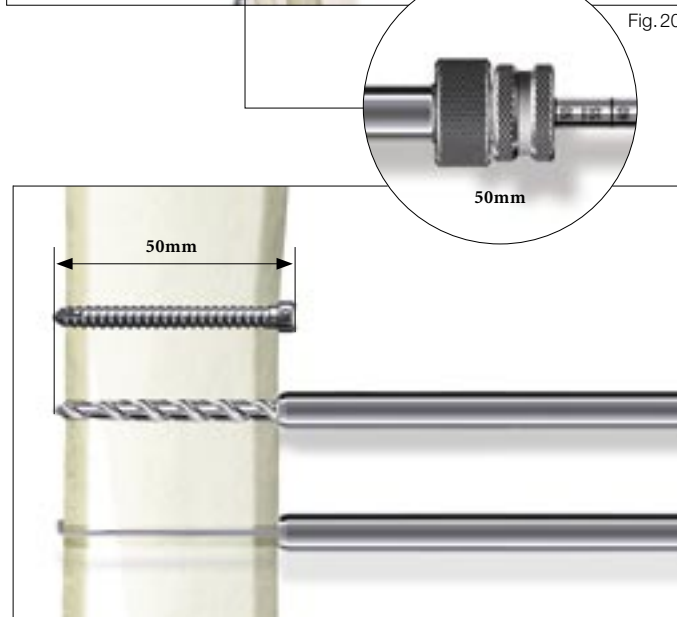

Fig. 21

## 4.9. Static Locking Mode

For static locking of the Standard Tibial Nail, both proximal oblique screws and the M/L Locking Screw may be used. In highly unstable, comminuted fractures the M/L screw is placed in the static position of the oblong hole. This may further improve stability of the proximal fragment.

If secondary dynamization is planned, the M/L screw may be inserted in the dynamic position of the oblong hole on the Target Device. This allows controlled dynamization of the fracture in cases of delayed union after removal of the proximal oblique screws.

### Note:

**If secondary dynamization is used with the Distal Tibial Nail, the M/L screw has to be inserted through the distal most part of the oblong hole the Target Device. (The oblong hole on the Distal Tibial Nail is 7mm more distal than on the Standard Tibial Nail).**

Always start with the most distal oblique Fully Threaded Locking Screw. The Short Tissue Protection Sleeve (assembled with the short Drill Sleeve and Trocar) is positioned through the static locking hole on the Target Device. A small skin incision is made, and while pressing the safety clip, the Tissue Protection Sleeve is pushed through until it is in contact with the anterior cortex (Fig. 19).

The Short Trocar is removed, with the Tissue Protection Sleeve and Drill Sleeve remaining in position.

# Operative Technique

For accurate drilling and easy determination of screw length, use the center-tipped, calibrated Ø4.2×260 Drill (1806-4250S). The centered Drill is forwarded through the Drill Sleeve and pushed onto the cortex.

After drilling both cortices, the screw length may be read directly off of the calibrated Drill at the end of the Drill Sleeve. If measurement with the Screw Gauge, Short is preferred, first remove the Drill Sleeve, Short and read the screw length directly at the end of the Tissue Protection Sleeve, Short (Fig. 20 and Fig. 21).

**Note:**

The position of the end of the Drill as it relates to the far cortex is equal to where the end of the screw will be. Therefore, if the end of the Drill is 3mm beyond the far cortex, the end of the screw will also be 3mm beyond.

**Note:**

The Screw Gauge, Short, is calibrated so that with the bend at the end pulled back flush with the far cortex, the screw tip will end 3mm beyond the far cortex (Fig. 21).

Alternatively, stop the drill when it engages the far cortex and measure the drill bit depth off of the calibrated drill. Add 5mm to this length to obtain the correct screw length.

When the Drill Sleeve is removed, the correct Locking Screw is inserted through the Tissue Protection Sleeve using the Short Screwdriver Shaft (1806-0222) with the Teardrop Handle (702429).

The screw is advanced through both cortices. The screw is near its' proper seating position when the groove around the shaft of the screwdriver is approaching the end of the Tissue Protection Sleeve (Fig. 22).

Repeat the locking procedure for the more proximal oblique Locking Screw (Fig. 23 and Fig. 24).



Fig. 22



Fig. 23



Fig. 24

# Operative Technique

## 4.10. Freehand Distal Locking

The freehand technique is used to insert Locking Screws into both the M/L and A/P holes in the nail. Rotational alignment must be checked prior to locking the nail statically.

Multiple locking techniques and radiolucent drill devices are available for freehand locking. The critical step with any freehand locking technique is to visualize a perfectly round locking hole with the C-Arm.

The center-tipped Ø4.2×130 Drill (1806-4280S) is held at an oblique angle pointing to the center of the locking hole (Fig. 25 and Fig. 26). Upon X-Ray verification, the Drill is placed perpendicular to the nail and drilled through the medial cortex. Confirm in both the A/P and M/L planes by X-Ray that the drill passes through the hole in the nail.



Fig. 25

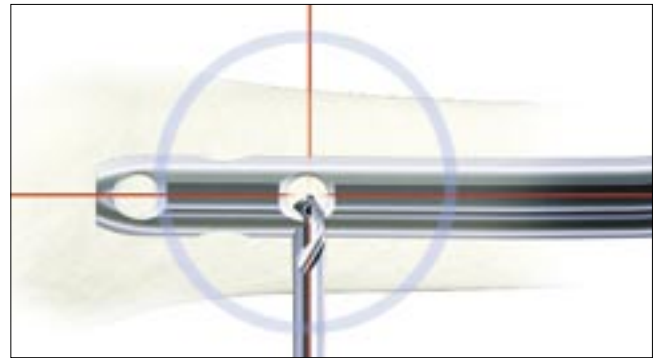
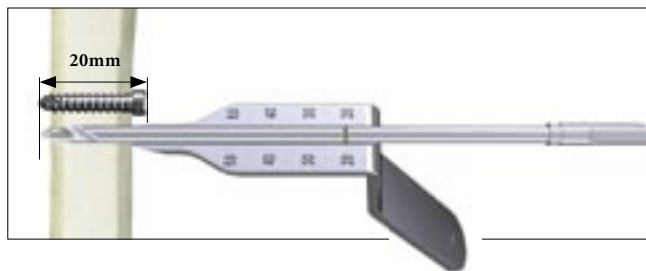

Fig. 26



After drilling both cortices the screw length may be read directly off of the calibrated Short Screw Scale (1806-0360) at the green ring on the center-tipped Drill (Fig. 27).

As detailed in the proximal locking section (Fig. 21, p. 14), the position of the end of the drill is equal to the end of the screw as they relate to the far cortex.

Routine Locking Screw insertion is employed (Fig. 28) with the assembled Screwdriver Shaft and Teardrop Handle.

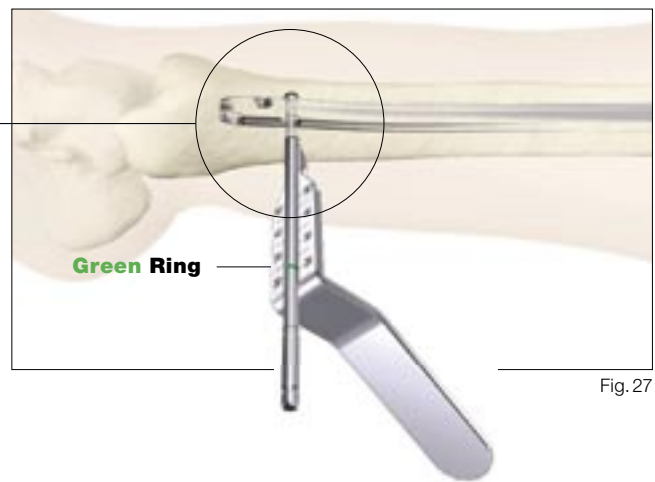

Fig. 27



Fig. 28

# Operative Technique

**Note:**

The Screwdriver Shaft may be used in conjunction with the “optional” Short Screw Capture Sleeve (1806-0245).

**Note:**

Distal locking should always be performed with two screws, locking the hole nearest the fracture site first. On the Standard and Proximal Tibial nails, always lock the most proximal M/L hole. The most distal hole of all three nail types is M/L. The next most proximal hole on all three nails is A/P. The Proximal and Standard Nails have a third more proximal M/L hole.

**Note:**

8mm Tibial Nails must always be locked distally with 4mm Fully Threaded Screws.

For the 8mm Tibial Nails, the Ø3.5×130 Drill (1806-3550S) is used to drill both cortices prior to inserting the 4mm Fully Threaded Locking Screws in the distal holes. **With all sizes of T2™ Tibial Nails, the 8mm Nails use 5.0 mm Screws proximally.**

### 4.11. End Cap Insertion

After removal of the Target Device, an End Cap is used. Eight different sizes of End Caps are available to adjust nail length and to reduce the potential for bony ingrowth into the proximal threads of the nail (Fig. 29).

The End Cap is inserted with the Screwdriver Shaft and Teardrop Handle after intra-operative radiographs show satisfactory reduction and hardware implantation (Fig. 30 and 31). Fully seat the End Cap to minimize the potential for loosening.

**Note:**

Thoroughly irrigate the wound to prevent debris from remaining within the knee joint. Close the wound using standard technique.



Fig. 30



Fig. 31



Fig. 29

# Operative Technique

## 4.12. Dynamic Locking Mode

When the fracture profile permits, dynamic locking may be utilized for transverse, axially stable fractures. Controlled dynamization is performed by statically locking the nail distally with at least two screws in a freehand technique.

**Note:**

The Proximal and Standard Nails each have one A/P and two M/L distal screw hole options. The Distal Nail has one M/L (the most distal) and one A/P distal screw hole.

In the Dynamic Locking Mode of the Standard Tibial Nail, the Partially Threaded Locking Screw (Shaft Screw) is placed in the dynamic position of the M/L oblong hole (Fig. 32). The two oblique proximal screws are not inserted. This allows the nail to move relative to the Partially Threaded Locking Screw (Shaft Screw) and the fracture to settle while maintaining torsional stability.

For screw insertion, follow the procedure described above (see Fig. 33 and 34).

**Note:**

When using the Distal Tibial Nail, the M/L screw has to be inserted in the static position of the oblong hole on the Targeting Device. It is important to note that the position of the oblong hole of this nail is 7mm more distal than on the Standard Nail.

**Note:**

When using the Distal Tibial Nail, static locking of the proximal M/L oblong hole can only be performed freehand.

**Note:**

Dynamic locking is not intended for and not possible with the Proximal Tibial Nail. There is no oblong hole in the nail.

**Note:**

The proximal end of the nail must be buried at least 7mm–12mm into the bone to reduce the potential for impingement or irritation of the Patellar Tendon if the nail migrates during dynamization.



Fig.32



Fig.33



Fig.34

# Operative Technique

## 4.13. Apposition/ Compression Locking Mode

In transverse or axially stable fracture patterns, active apposition/compression increases fracture stability, may enhance fracture healing and allow for early weight bearing. **The T2™ Standard Tibial Nail and T2™ Distal Tibial Nail** provide the option to treat a tibial fracture with active mechanical apposition/compression prior to leaving the operating room.

**Note:**  
**Distal freehand static locking with at least two screws must be performed prior to applying active, controlled apposition/compression to the fracture site.**

If active apposition/compression is required for the T2 Standard Tibial Nail, a Partially Threaded Locking Screw is inserted via the Target Device in the dynamic position of the of the oblong hole. The Distal Tibial Nail uses the static position of the oblong hole.

This will allow for a maximum of 7mm of active, controlled apposition/compression. In order to insert the **Partially Threaded Locking Screw (Shaft Screw)**, drill both cortices with the Ø4.2×260 Drill (1806-4250S). Correct screw length may be read from the calibration on the Drill at the end of the Drill Sleeve. The **near cortex ONLY is overdrilled** using the Ø5×180mm Drill (1806-5010S).

**Note:**  
It may be easier to **insert the Compression Screw** prior to fully seating the nail. Once the nail tip has cleared the fracture site, the guide wire (if used) is withdrawn. With the proximal portion of the nail still not fully seated and extending out of the bone, the Nail Holding Screw is removed and the Compression Screw is inserted. Care should be taken that the shaft of the Compression Screw does not extend into the area of the oblong hole.

Another alternative is that after the Partially Threaded Locking Screw (Shaft Screw) is inserted, the Nail Holding Screw securing the nail to the insertion post is removed, leaving the insertion post intact with the nail (Fig. 35). This will act as a guide for the Compression Screw (Fig. 36).

The Compression Screw is inserted with the Compression Screwdriver Shaft (1806-0268) assembled on the Teardrop Handle through the insertion post. When the ring marked with a “T” on the Compression Screwdriver Shaft is close to the Target Device, it indicates the engagement of the apposition/compression feature of the nail.

**Note:**  
**The ring marked with an “F” is for the Femoral Compression Screw.**

The Short Tissue Protection Sleeve is removed and the Compression Screw is gently tightened utilizing the two-finger technique. As the Compression Screw is advanced against the 5.0mm Partially Threaded Locking Screw (Shaft Screw), it draws the distal fracture segment towards the fracture site, employing active apposition/compression (Fig. 37). Image intensification will enable the surgeon to visualize active apposition/compression. Some bending of the Partially Threaded Locking Screw may be seen.

**Note:**  
Prior to compressing the fracture, the nail must be countersunk a safe distance from the entry point to accommodate for the 7mm of active compression. The three grooves on the insertion post help attain accurate insertion depth of the implant.

**Note:**  
**Apposition/compression should be carried out under fluoroscopy. Overtightening of the Compression Screw onto the Partially Threaded Locking Screw (Shaft Screw) may result in the screw to fail.**



Fig. 35



Fig. 36



Fig. 37

# Operative Technique

## 4.14. Advanced Locking Mode

In order to achieve additional fixation, and to reduce the load on the Partially Threaded Locking Screw, the design of the **T2™ Standard Tibial Nail** and **T2™ Distal Tibial Nail** provide the opportunity to insert an additional Fully Threaded Locking Screw (Shaft Screw) into the more proximal of the two oblique holes after the optimum amount of apposition/compression is attained.

Affix the Compression Screw onto the self-retaining Compression Screwdriver Shaft. Remove the Nail Holding Screw leaving the Target Device in place. Advance the Compression Screw through the Target Device until the ring marked with a “T” on the Compression Screwdriver Shaft is close to the Target Device and compression is applied (Fig. 38).

To insert the Advanced Compression Screw, follow the procedure under 4.13 on page 19.

### **Note:**

As previously described, it may be easier to insert the Compression Screw prior to fully seating the nail.

To reattach the Target Device, detach the Teardrop Handle from the Compression Screwdriver Shaft and screw the Nail Holding Screw over the Compression Screwdriver Shaft back into position (Fig. 39).

Prior to guided locking via the Target Device, the Nail Holding Screw must be securely tightened with the Insertion Wrench.

### **Note:**

When using the Advanced Compression Screw, only the more proximal oblique hole can be locked with a screw. The more distal oblique hole will be partially blocked by the top of the Advanced Compression Screw regardless of the amount of compression applied to the Shaft Screw in the M/L oblong hole.



Fig. 38



Fig. 39



Fig. 40

# Operative Technique

To insert the proximal oblique Fully Threaded Locking Screw, follow the locking procedure for static locking (see Fig. 40 and step 4.9 on page 14).

## 4.15. Nail Removal

Nail removal is an elective procedure.

If needed, the End Cap and Advanced Compression Screw are removed with the Screwdriver Shaft and Teardrop Handle. If the Advanced Locking Mode was utilized, first remove the End Cap, then the most proximal screw, then the Advanced Compression Screw can be removed (Fig. 41).

### Note:

As an alternative to removing the Advanced Compression Screw (if used), it can be just disengaged from the Partially Threaded Locking Screw (Shaft Screw) by turning the Compression Screwdriver one full turn in a counter-clockwise direction. There is no need to remove it from the nail.

### Note:

DO NOT remove the last proximal Locking Screw prior to attaching the Universal Rod to the proximal end of the nail. Doing so may result in the nail moving posteriorly, making it difficult to attach the Universal Rod to the nail.

The Universal Rod is inserted into the driving end of the nail. All Locking Screws are removed with the Short Screwdriver Shaft and Teardrop Handle (Fig. 42).

### Note:

The Screwdriver Shaft may be used in conjunction with the “optional” Screw Capture Sleeve, Short (1806-0245).

The Slotted Hammer or optional Sliding Hammer is used to extract the nail in a controlled manner (Fig. 43).

Close the wound in the usual manner.



Fig. 41



Fig. 42



Fig. 43

# Blocking Screw Technique (optional)

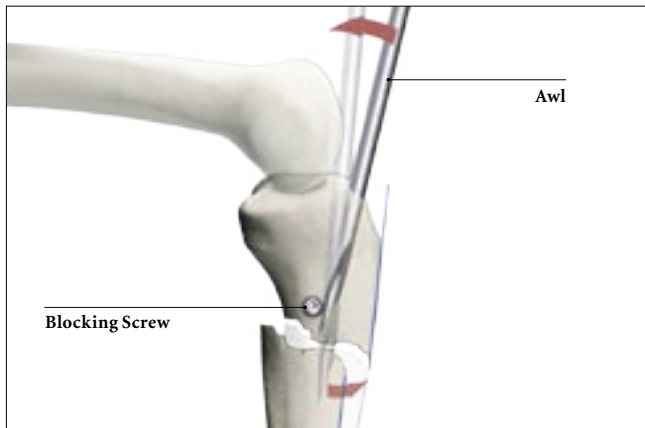

Fig. 44

## Mechanics of Blocking Screw

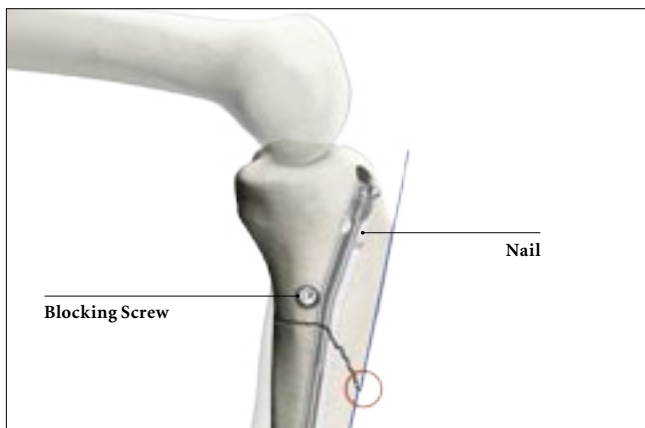

Fig. 45

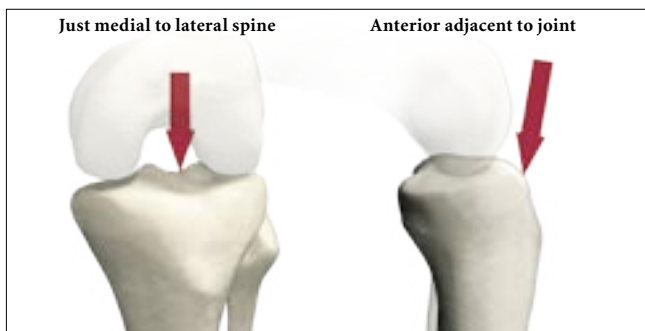

Fig. 46

## Superolateral Entry Portal

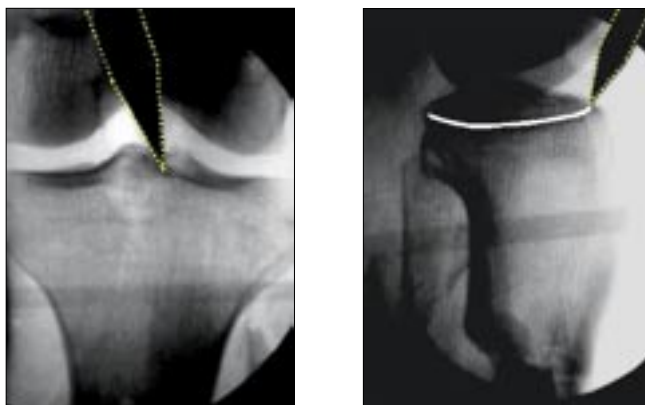

Fig. 47

## Radiographic location of Superolateral Nail Entry Portal

# Blocking Screw Technique (optional)



Fig. 48

The nail often sits against the posterior cortex which causes anterior angulation of the fracture because the shaft position is fixed by the nail (Fig. 48).



Fig. 49

The principle of the use of a Blocking Screw is to prevent posterior nail passage by decreasing the effective diameter of the canal and directing the nail more anterior as shown



Fig. 50

(Fig. 49). Using the superolateral entry point and with the Blocking Screw in place, the nail accurately aligns the shaft (fracture) (Fig. 50) (6, 7, 8)



Fig. 51a

## For Varus/Valgus Adjustment

One of the advantages of the very proximal bend in the nail, is its' usefulness in correcting varus/valgus angulation. Do not lock the nail distally until after angular correction.

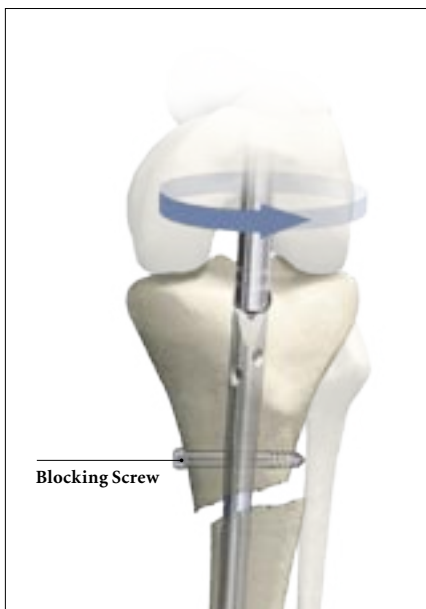

Fig. 51b

Place the Blocking Screw at the level of the Proximal (Herzog) Bend (Fig. 51a). In cases where a Blocking Screw is used, simple rotation of the nail (Fig. 51b) will allow the Herzog Bend to correct the angulation (Fig. 51c).

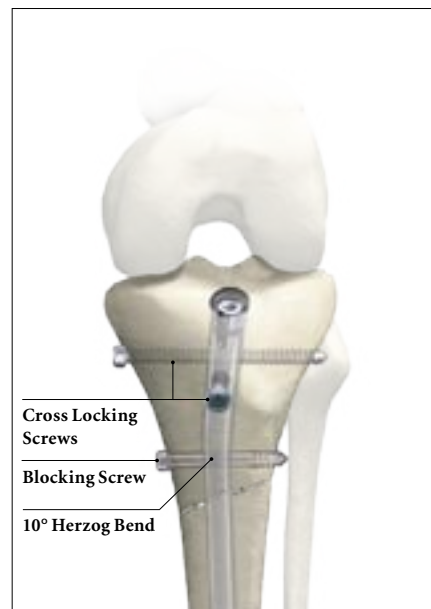

Fig. 51c

## Note:

As an option, or in an exchange/revision nailing with a more distal entry portal, this principle can also be applied with a Lateral Blocking Screw placed A/P as an alternative method to help prevent Varus/Valgus deformity.

# Ordering Information - Implants

## T2 Standard Tibial Nail



REF	Diameter mm	Length mm	REF	Diameter mm	Length mm
1822-0924S	9.0	240	1822-1424S	14.0	240
1822-0925S	9.0	255	1822-1425S	14.0	255
1822-0927S	9.0	270	1822-1427S	14.0	270
1822-0928S	9.0	285	1822-1428S	14.0	285
1822-0930S	9.0	300	1822-1430S	14.0	300
1822-0931S	9.0	315	1822-1431S	14.0	315
1822-0933S	9.0	330	1822-1433S	14.0	330
1822-0934S	9.0	345	1822-1434S	14.0	345
1822-0936S	9.0	360	1822-1436S	14.0	360
1822-0937S	9.0	375	1822-1437S	14.0	375
1822-0939S	9.0	390	1822-1439S	14.0	390
1822-0940S	9.0	405	1822-1440S	14.0	405
1822-0942S	9.0	420	1822-1442S	14.0	420
1822-1024S	10.0	240	1822-1524S	15.0	240
1822-1025S	10.0	255	1822-1525S	15.0	255
1822-1027S	10.0	270	1822-1527S	15.0	270
1822-1028S	10.0	285	1822-1528S	15.0	285
1822-1030S	10.0	300	1822-1530S	15.0	300
1822-1031S	10.0	315	1822-1531S	15.0	315
1822-1033S	10.0	330	1822-1533S	15.0	330
1822-1034S	10.0	345	1822-1534S	15.0	345
1822-1036S	10.0	360	1822-1536S	15.0	360
1822-1037S	10.0	375	1822-1537S	15.0	375
1822-1039S	10.0	390	1822-1539S	15.0	390
1822-1040S	10.0	405	1822-1540S	15.0	405
1822-1042S	10.0	420	1822-1542S	15.0	420
1822-1124S	11.0	240			
1822-1125S	11.0	255			
1822-1127S	11.0	270			
1822-1128S	11.0	285			
1822-1130S	11.0	300			
1822-1131S	11.0	315			
1822-1133S	11.0	330			
1822-1134S	11.0	345			
1822-1136S	11.0	360			
1822-1137S	11.0	375			
1822-1139S	11.0	390			
1822-1140S	11.0	405			
1822-1142S	11.0	420			
1822-1224S	12.0	240			
1822-1225S	12.0	255			
1822-1227S	12.0	270			
1822-1228S	12.0	285			
1822-1230S	12.0	300			
1822-1231S	12.0	315			
1822-1233S	12.0	330			
1822-1234S	12.0	345			
1822-1236S	12.0	360			
1822-1237S	12.0	375			
1822-1239S	12.0	390			
1822-1240S	12.0	405			
1822-1242S	12.0	420			
1822-1324S	13.0	240			
1822-1325S	13.0	255			
1822-1327S	13.0	270			
1822-1328S	13.0	285			
1822-1330S	13.0	300			
1822-1331S	13.0	315			
1822-1333S	13.0	330			
1822-1334S	13.0	345			
1822-1336S	13.0	360			
1822-1337S	13.0	375			
1822-1339S	13.0	390			
1822-1340S	13.0	405			
1822-1342S	13.0	420			

Implants in sterile packaging

**Note:**  
Check with local representative regarding availability of nail sizes and types.

# Ordering Information - Implants

## T2™ Proximal Tibial Nail



REF	Diameter mm	Length mm	REF	Diameter mm	Length mm
1823-0924S	9.0	240	1823-1424S	14.0	240
1823-0925S	9.0	255	1823-1425S	14.0	255
1823-0927S	9.0	270	1823-1427S	14.0	270
1823-0928S	9.0	285	1823-1428S	14.0	285
1823-0930S	9.0	300	1823-1430S	14.0	300
1823-0931S	9.0	315	1823-1431S	14.0	315
1823-0933S	9.0	330	1823-1433S	14.0	330
1823-0934S	9.0	345	1823-1434S	14.0	345
1823-0936S	9.0	360	1823-1436S	14.0	360
1823-0937S	9.0	375	1823-1437S	14.0	375
1823-0939S	9.0	390	1823-1439S	14.0	390
1823-0940S	9.0	405	1823-1440S	14.0	405
1823-0942S	9.0	420	1823-1442S	14.0	420
1823-1024S	10.0	240	1823-1524S	15.0	240
1823-1025S	10.0	255	1823-1525S	15.0	255
1823-1027S	10.0	270	1823-1527S	15.0	270
1823-1028S	10.0	285	1823-1528S	15.0	285
1823-1030S	10.0	300	1823-1530S	15.0	300
1823-1031S	10.0	315	1823-1531S	15.0	315
1823-1033S	10.0	330	1823-1533S	15.0	330
1823-1034S	10.0	345	1823-1534S	15.0	345
1823-1036S	10.0	360	1823-1536S	15.0	360
1823-1037S	10.0	375	1823-1537S	15.0	375
1823-1039S	10.0	390	1823-1539S	15.0	390
1823-1040S	10.0	405	1823-1540S	15.0	405
1823-1042S	10.0	420	1823-1542S	15.0	420
1823-1124S	11.0	240			
1823-1125S	11.0	255			
1823-1127S	11.0	270			
1823-1128S	11.0	285			
1823-1130S	11.0	300			
1823-1131S	11.0	315			
1823-1133S	11.0	330			
1823-1134S	11.0	345			
1823-1136S	11.0	360			
1823-1137S	11.0	375			
1823-1139S	11.0	390			
1823-1140S	11.0	405			
1823-1142S	11.0	420			
1823-1224S	12.0	240			
1823-1225S	12.0	255			
1823-1227S	12.0	270			
1823-1228S	12.0	285			
1823-1230S	12.0	300			
1823-1231S	12.0	315			
1823-1233S	12.0	330			
1823-1234S	12.0	345			
1823-1236S	12.0	360			
1823-1237S	12.0	375			
1823-1239S	12.0	390			
1823-1240S	12.0	405			
1823-1242S	12.0	420			
1823-1324S	13.0	240			
1823-1325S	13.0	255			
1823-1327S	13.0	270			
1823-1328S	13.0	285			
1823-1330S	13.0	300			
1823-1331S	13.0	315			
1823-1333S	13.0	330			
1823-1334S	13.0	345			
1823-1336S	13.0	360			
1823-1337S	13.0	375			
1823-1339S	13.0	390			
1823-1340S	13.0	405			
1823-1342S	13.0	420			

Implants in sterile packaging

Proximal Tibial Nails available as Special Order.

**Note:**

Check with local representative regarding availability of nail sizes and types.

# Ordering Information - Implants

## T2 Distal Tibial Nail



REF	Diameter mm	Length mm
1824-1024S	10.0	240
1824-1025S	10.0	255
1824-1027S	10.0	270
1824-1028S	10.0	285
1824-1030S	10.0	300
1824-1031S	10.0	315
1824-1033S	10.0	330
1824-1034S	10.0	345
1824-1036S	10.0	360
1824-1037S	10.0	375
1824-1039S	10.0	390
1824-1040S	10.0	405
1824-1042S	10.0	420

## 5mm Fully Threaded Locking Screws\*



REF	Diameter mm	Length mm
1896-5025S	5.0	25.0
1896-5027S	5.0	27.5
1896-5030S	5.0	30.0
1896-5032S	5.0	32.5
1896-5035S	5.0	35.0
1896-5037S	5.0	37.5
1896-5040S	5.0	40.0
1896-5042S	5.0	42.5
1896-5045S	5.0	45.0
1896-5047S	5.0	47.5
1896-5050S	5.0	50.0
1896-5052S	5.0	52.5
1896-5055S	5.0	55.0
1896-5057S	5.0	57.5
1896-5060S	5.0	60.0
1896-5065S	5.0	65.0
1896-5070S	5.0	70.0
1896-5075S	5.0	75.0
1896-5080S	5.0	80.0
1896-5085S	5.0	85.0
1896-5090S	5.0	90.0
1896-5095S	5.0	95.0
1896-5100S	5.0	100.0
1896-5105S	5.0	105.0
1896-5110S	5.0	110.0
1896-5115S	5.0	115.0
1896-5120S	5.0	120.0

## 5mm Partially Threaded Locking Screws\*



REF	Diameter mm	Length mm
1891-5025S	5.0	25
1891-5030S	5.0	30
1891-5035S	5.0	35
1891-5040S	5.0	40
1891-5045S	5.0	45
1891-5050S	5.0	50
1891-5055S	5.0	55
1891-5060S	5.0	60
1891-5065S	5.0	65
1891-5070S	5.0	70
1891-5075S	5.0	75
1891-5080S	5.0	80
1891-5085S	5.0	85
1891-5090S	5.0	90
1891-5095S	5.0	95
1891-5100S	5.0	100
1891-5105S	5.0	105
1891-5110S	5.0	110
1891-5115S	5.0	115
1891-5120S	5.0	120

## Shaft Screws

## 4mm Fully Threaded Locking Screws



REF	Diameter mm	Length mm
1896-4020S	4.0	20
1896-4025S	4.0	25
1896-4030S	4.0	30
1896-4035S	4.0	35
1896-4040S	4.0	40
1896-4045S	4.0	45
1896-4050S	4.0	50
1896-4055S	4.0	55
1896-4060S	4.0	60

Distal Tibial Nails available as Special Order

\* Outside of the U.S., Locking Screws may be ordered non-sterile without the "S" at the end of the corresponding Catalogue Number.

# Ordering Information - Implants

## 8mm Tibial Nail, Standard



REF	Diameter mm	Length mm
1822-0824S	8.0	240
1822-0825S	8.0	255
1822-0827S	8.0	270
1822-0828S	8.0	285
1822-0830S	8.0	300
1822-0831S	8.0	315
1822-0833S	8.0	330
1822-0834S	8.0	345
1822-0836S	8.0	360
1822-0837S	8.0	375
1822-0839S	8.0	390
1822-0840S	8.0	405
1822-0842S	8.0	420

## 8mm Tibial Nail, Proximal



REF	Diameter mm	Length mm
1823-0824S	8.0	240
1823-0825S	8.0	255
1823-0827S	8.0	270
1823-0828S	8.0	285
1823-0830S	8.0	300
1823-0831S	8.0	315
1823-0833S	8.0	330
1823-0834S	8.0	345
1823-0836S	8.0	360
1823-0837S	8.0	375
1823-0839S	8.0	390
1823-0840S	8.0	405
1823-0842S	8.0	420

## End Caps

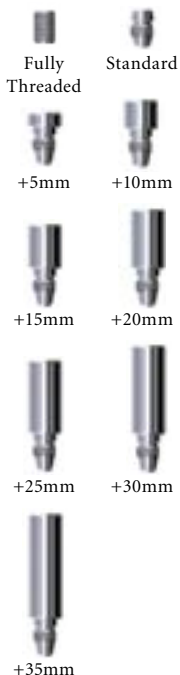

REF	Diameter mm	Length mm
1822-0004S	7.0	Fully Threaded
1822-0003S	8.0	Standard
1822-0005S	11.5	+ 5mm
1822-0010S	11.5	+10mm
1822-0015S	11.5	+15mm
1822-0020S	11.5	+20mm
1822-0025S	11.5	+25mm
1822-0030S	11.5	+30mm
1822-0035S	11.5	+35mm

## Advanced Compression Screws, Tibia



REF	Diameter mm	Length mm
1822-0001S	8.0	











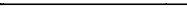



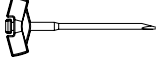
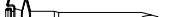















Implants in sterile packaging

**Note:**  
Check with local representative regarding availability of nail sizes and types.

Partially Threaded Locking Screws (Shaft Screws) are used in conjunction with the Advanced Compression Screw feature of the Distal and Standard Nails, or may also be used as a "Blocking Screw" with all three nail types, including the Proximal Nail.











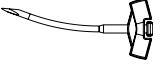







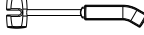

(See optional "Blocking Screw Technique" section on pages 22 and 23)



# Ordering Information - Instruments

REF	Description	REF	Description
<b>T2 8mm Tibial Nail Instruments</b>		<b>Standard Instruments</b>	
	1806-0073S Teflon Tube (for 8mm Nail Guide Wire exchange ONLY)	1806-6000	T2™ Tibial Instrument Set, Basic
	1806-0090 Guide Wire, Smooth Tip 3×800 mm (outside of U.S.)		1806-0010 X-Ray Ruler, Tibia
	1806-0090S Guide Wire, Smooth Tip 3×800 mm, sterile (U.S.)		1806-0020 Guide Wire Ruler (for 800 or 1000mm Guidewires)
	1806-3550 Drill Ø3.5×130mm AO (outside of U.S.)		1806-0045 Awl, Straight, Ø10mm
	1806-3550S Drill Ø3.5×130mm AO, sterile (U.S.)		1806-0050 K-Wire 3×285mm
	1806-3555 Drill Ø3.5×130mm Tri-flat (outside of U.S.)		1806-0095 Guide Wire Handle
	1806-3555S Drill Ø3.5×130mm Tri-flat, sterile (outside of U.S.)		1806-0096 Guide Wire Handle Chuck
1806-0430	Short Drill Sleeve Ø 3.5mm		1806-0110 Universal Rod
			1806-0125 Reduction Spoon
			1806-0130 Wrench 8mm/10mm
			1806-0135 Insertion Wrench, 10mm
			1806-0150 Strike Plate
			1806-0170 Slotted Hammer
			1806-0180 Tissue Protection Sleeve, Short
			1806-0210 Drill Sleeve, Short
			1806-0222 Screwdriver Shaft, AO, Short
			1806-0268 Screwdriver Shaft, AO, Compression
			1806-0292 Screwdriver Shaft, AO, 3.5×85mm
			1806-0310 Trocar, Short
			1806-0330 Screw Gauge, Short
			1806-0360 Screw Scale, Short
			1806-0370 Nail Holding Screw, Tibia
			1806-1000 Target Device, Tibia (2 Components)
			1806-2010 Rigid Reamer, Ø10mm
			1806-4250 Drill Ø4.2×260, AO, (outside of U.S.)
			1806-4280 Drill Ø4.2×130, AO, (outside of U.S.)
			1806-5010 Drill Ø5.0×180, AO, (outside of U.S.)
			1806-9020 Tibia Instrument Tray
			702429 Teardrop Handle, AO coupling

Instruments designated "Outside of the U.S." may not be ordered for the U.S. market.

# Ordering Information - Instruments

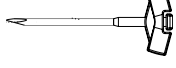
REF	Description
<b>Optional</b>	
1806-0000	X-Ray Template, Standard and Proximal Nails (TNS and TNP)
1806-0001	X-Ray Template, Tibial Nail Distal (TND)
 1806-0032	Awl Plug
 1806-0040	Awl, Curved, Ø10mm
 1806-0050S	K-Wire 3×285mm, sterile (U.S.)
 1806-0073S	Teflon Tube (for 8mm Nail Guide Wire exchange ONLY)
 1806-0080	Guide Wire, Ball Tip, 3×800 mm, (outside of U.S.)
 1806-0080S	Guide Wire, Ball Tip, 3×800 mm, sterile (U.S.)
 1806-0085	Guide Wire, Ball Tip, 3×1000 mm, (outside of U.S.)
 1806-0085S	Guide Wire, Ball Tip, 3×1000 mm, sterile, (U.S.)
 1806-0090	Guide Wire, Smooth, 3×800 mm, (outside of U.S.)
 1806-0090S	Guide Wire, Smooth, 3x800 mm, sterile (U.S.)
 1806-0175	Sliding Hammer
 1806-0232	Screwdriver, Long
 1806-0237	Screwdriver, Short
 1806-0245	Screw Capture Sleeve, Short
 1806-0270	Ratchet T-Handle, AO
 1806-0300	Screwdriver Shaft, AO, Ball Tip
 1806-0350	Extraction Rod, Conical, Ø8mm
 1806-0480	Long Screw Gauge (20mm–80mm)
 1806-4250S	Drill Ø4.2×260, AO, sterile (U.S.)
 1806-4280S	Drill Ø4.2×130, AO, sterile (U.S.)
 1806-4285	Drill Ø4.2×130, Tri-flat, (outside of U.S.)
 1806-5010S	Drill Ø5.0×180, AO, sterile (U.S.)
 1806-5015	Drill Ø5.0×180, Tri-flat, (outside of U.S.)
1806-9010	Screw Tray

REF	Description
<b>Special Order Items</b>	
 702427	T-Handle, AO Coupling
703166	Freehand Drill Sleeve
0140-0002	Reaming Protector
 1806-0047	Awl, Straight, Ø11.5 mm
1806-0120	Reduction Tip
1806-0202	Screwdriver, Extra Short
1806-0340	Extraction Adapter
1806-0390	Depth Gauge, Standard Style for freehand locking (20mm–60mm)
1806-0420	Short Drill Sleeve Ø 4.2mm
1806-0425	Short Freehand Tissue Protection Sleeve
 1806-2011	Rigid Reamer, Ø11.5 mm

Instruments designated “Outside of the U.S.” may not be ordered for the U.S. market.

# Ordering Information - Instruments

Bixcut™

**Complete range of modular and fixed-head reamers to match surgeon preference and optimize O. R. efficiency, presented in fully sterilizable cases.**

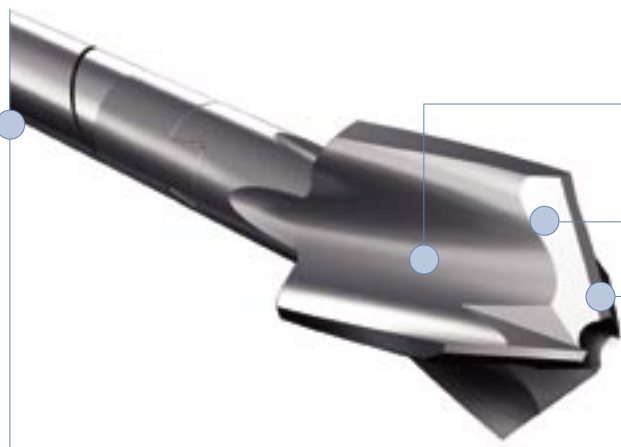

Large clearance rate resulting from reduced number of reamer blades coupled with reduced length of reamer head to give effective relief of pressure and efficient removal of material.

Cutting flute geometry optimized to lower pressure generation.

Forward- and side-cutting face combination produces efficient material removal and rapid clearance.

Double-wound shaft transmits torque effectively and with high reliability. Low-friction surface finish aids rapid debris clearance.

Smaller, 6 and 8mm shaft diameters significantly reduce IM pressure.

**Typical Standard**  
Reamer Ø14mm

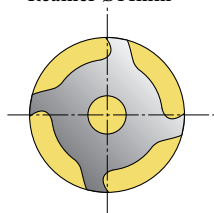

Clearance area:  
32% of cross section

**Bixcut™**  
Reamer Ø14mm

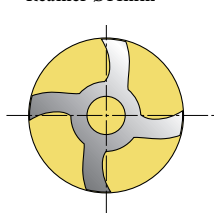

Clearance area:  
59% of cross section

Recent studies<sup>1</sup> have demonstrated that the pressures developed within the medullary cavity through the introduction of unreamed IMnails can be far greater than those developed during reaming – but this depends very much upon the design of the reamer.

After a three year development study<sup>2</sup> involving several universities, the factors that determine the pressures and temperatures developed during reaming were clearly established. These factors were applied to the development of advanced reamers that demonstrate significantly better performance than the best of previous designs.

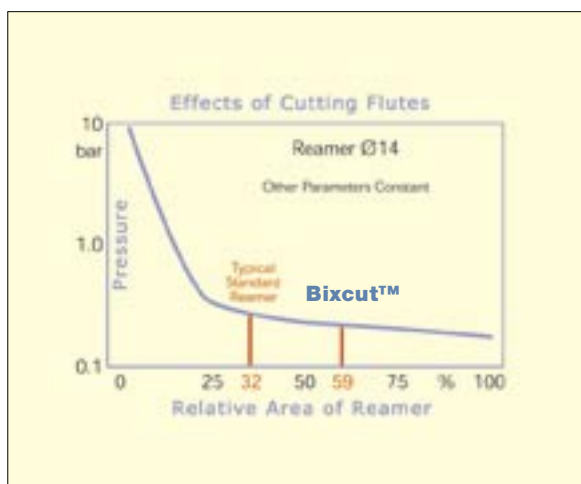

<sup>1</sup> Jan Paul M. Frolke, et al.; Intramedullary Pressure in Reamed Femoral Nailing with Two Different Reamer Designs., Eur. J. of Trauma, 2001 #5

<sup>2</sup> Medhi Massau, et al.; Pressure Changes During Reaming with Different Parameters and Reamer Designs, Clinical Orthopaedics and Related Research Number 373, pp. 295-303, 2000

# Ordering Information - Instruments

## Bixcut™ Modular Head

REF	Description	Diameter mm
0226-3090	Bixcut Head	9.0
0226-3095	Bixcut Head	9.5
0226-3100	Bixcut Head	10.0
0226-3105	Bixcut Head	10.5
0226-3110	Bixcut Head	11.0
0226-3115	Bixcut Head	11.5
0226-3120	Bixcut Head	12.0
0226-3125	Bixcut Head	12.5
0226-3130	Bixcut Head	13.0
0226-3135	Bixcut Head	13.5
0226-3140	Bixcut Head	14.0
0226-3145	Bixcut Head	14.5
0226-3150	Bixcut Head	15.0
0226-3155	Bixcut Head	15.5
0226-3160	Bixcut Head	16.0
0226-3165	Bixcut Head	16.5
0226-3170	Bixcut Head	17.0
0226-3175	Bixcut Head	17.5
0226-3180	Bixcut Head	18.0
0226-4185	Bixcut Head	18.5
0226-4190	Bixcut Head	19.0
0226-4195	Bixcut Head	19.5
0226-4200	Bixcut Head	20.0
0226-4205	Bixcut Head	20.5
0226-4210	Bixcut Head	21.0
0226-4215	Bixcut Head	21.5
0226-4220	Bixcut Head	22.0
0226-4225	Bixcut Head	22.5
0226-4230	Bixcut Head	23.0
0226-4235	Bixcut Head	23.5
0226-4240	Bixcut Head	24.0
0226-4245	Bixcut Head	24.5
0226-4250	Bixcut Head	25.0
0226-4255	Bixcut Head	25.5
0226-4260	Bixcut Head	26.0
0226-4265	Bixcut Head	26.5
0226-4270	Bixcut Head	27.0
0226-4275	Bixcut Head	27.5
0226-4280	Bixcut Head	28.0

## Bixcut™ Shaft – AO fitting

REF	Description	Length mm
0226-3000	Shaft, AO	450
0226-8240	Shaft, AO	240

## Bixcut™ Shaft – Modified Trinkle fitting (sterile)+

REF	Description	Length mm
0227-3000(S)	Shaft, Mod. Trinkle	450
0227-8240(S)	Shaft, Mod. Trinkle	240

## Bixcut™ Trays

REF	Description
0225-6000	Tray, Modular Head (up to size 22.0mm)
0225-6001	Tray, Modular Head (up to size 28.0mm)
0225-8000	Tray, Fixed Head (up to size 18.0mm)

## Bixcut™ Fixed Head – AO fitting

REF	Diameter mm	Length mm
0225-5060	6.0*	400
0225-5065	6.5*	400
0225-5070	7.0*	400
0225-6075	7.5	480
0225-6080	8.0	480
0225-6085	8.5	480
0225-6090	9.0	480
0225-6095	9.5	480
0225-6100	10.0	480
0225-6105	10.5	480
0225-6110	11.0	480
0225-8115	11.5	480
0225-8120	12.0	480
0225-8125	12.5	480
0225-8130	13.0	480
0225-8135	13.5	480
0225-8140	14.0	480
0225-8145	14.5	480
0225-8150	15.0	480
0225-8155	15.5	480
0225-8160	16.0	480
0225-8165	16.5	480
0225-8170	17.0	480
0225-8175	17.5	480
0225-8180	18.0	480

## Bixcut™ Fixed Head – Modified Trinkle fitting+

REF	Diameter mm	Length mm
0227-5060	6.0*	400
0227-5065	6.5*	400
0227-5070	7.0*	400
0227-6075	7.5	480
0227-6080	8.0	480
0227-6085	8.5	480
0227-6090	9.0	480
0227-6095	9.5	480
0227-6100	10.0	480
0227-6105	10.5	480
0227-6110	11.0	480
0227-8115	11.5	480
0227-8120	12.0	480
0227-8125	12.5	480
0227-8130	13.0	480
0227-8135	13.5	480
0227-8140	14.0	480
0227-8145	14.5	480
0227-8150	15.0	480
0227-8155	15.5	480
0227-8160	16.0	480
0227-8165	16.5	480
0227-8170	17.0	480
0227-8175	17.5	480
0227-8180	18.0	480

+ Use with Stryker Power Equipment

\* Use with 2.2mm × 800mm Smooth Tip and 2.5mm × 800mm Ball Tip Guide wires only.

